

BIANCO NXT

accessories

Bianco NXT FSK1.1 Float Switch H07RN-F Series Pump Floats

BIA-FSK1.1(10M) – 801125

Instruction Manual



Introduction

The **Bianco NXT FSK1.1** is an H07 neoprene-cable float switch suited to clean water and grey water applications – rainwater harvesting, stormwater, irrigation, and general sump duty.

For sewage, black water, or chemically aggressive liquids, this highly buoyant model is superb.

The FSK1.1 is a 3-wire float which can be wired to provide a ‘normally open’ or ‘normally closed’ control circuit.

Float switches are an uncomplicated electrical accessory, and the purpose of this manual is both to ensure user safety and highlight ‘best practice’.

Technical Specifications

CURRENT RATING	Max. 16A resistive, 8A inductive	RATED VOLTAGE	125 – 250VAC 50/60Hz
CABLE TYPE	H07RN-F neoprene	CABLE LENGTH	10 m
WORKING TEMPERATURE	< 50°C	PROTECTION CLASS	IP68



The user is responsible for ensuring the connected load does not exceed the float switch’s rated current capacity (16A resistive / 8A inductive).

Where cables are used at mains voltage (230V), voltage drop across longer cable lengths should be considered. Appropriate wiring practices must be observed to ensure safe and reliable operation.



The power supply cable is an integral part of the float switch. Repairs to the cable itself are not possible, and if the cable is damaged, the float must be replaced. Water ingress to the cable will affect operation.



The terminal end of the cable must never be immersed into water.
The wire that is not used must be correctly terminated and insulated.

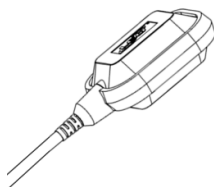

Brown/Black Up is On
Blue/Black Up is Off

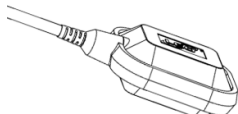

Blue/Black Down is On
Brown/Black Down is Off

The most common use for these float switches is as a low voltage switched control circuit connected to a secondary control unit.

Ensure the connection to the controller provide the correct input state.

Installation



Ensure the float is mounted with sufficient free cable length to swing freely. Cable stiffness can restrict movement and cause unreliable operation.

Where multiple floats are installed, a float tree or dedicated mounting pipe provides a clean, reliable solution for positioning each float at the correct operating depth.

If necessary, attach a float counterweight to reduce the cable length required for the float to tip and activate.

Counterweights are available on request – BIA-SK12CWB: PN 700967.

The length of the cable between the counterweight (if used) or the cable fixation point and the float head determines the operating level.



IMPORTANT: The terminal end of the electrical cable should never be immersed into water during installation.

Counterweight installation (optional)

Remove the cap and rubber compression ring. Slide the cap, compression ring and counterweight onto the float cable. Position the counterweight in the desired position and tighten the cap onto the compression rubber to fix in position.

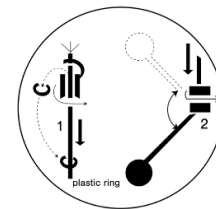

Interrupter switch operation



The user is responsible for ensuring the connected load does not exceed the float switch's rated current capacity (8A inductive).

Instructions for water-filling

Connect the blue wire of the float switch to the pump and the black one to a neutral wire as shown in the diagram.

The brown wire should be kept insulated. The images below show how the pump begins to pump water when the water in the tank drops to a certain level and stops when the water rises to a certain level.

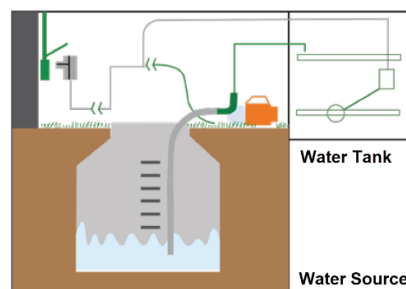
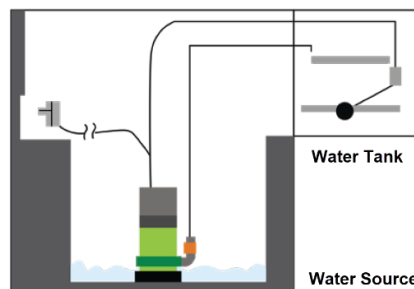
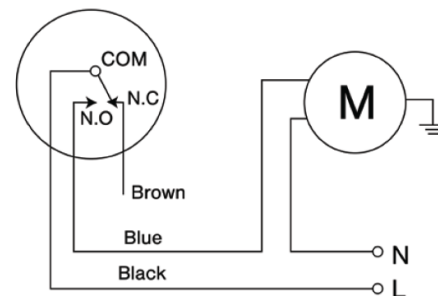

Instructions for water-emptying

Connect the **brown** wire to the pump and the **black** one to the neutral wire as shown in the adjacent diagram. The **blue** wire should be kept insulated.

In the figures below, the pump stops when the level in the water pool drops to a certain level and starts pumping out water again when the water level increases.

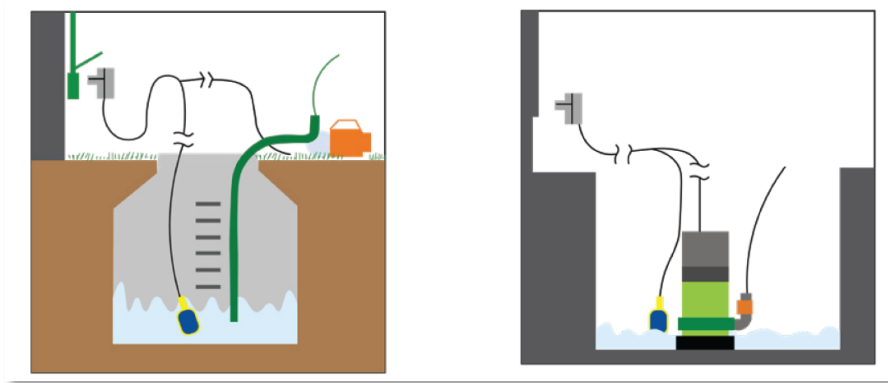
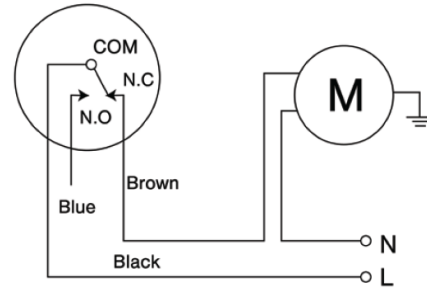

Automated filling and emptying

An extension of the 2 previous functions is to wire the float in a manner to control dual pumps.



This diagram shows the wiring for an auto-changeover between filling and emptying water.

Connect the **black** wire of the float to the line phase connection.

Connect the **blue** wire to the auto-fill pump.

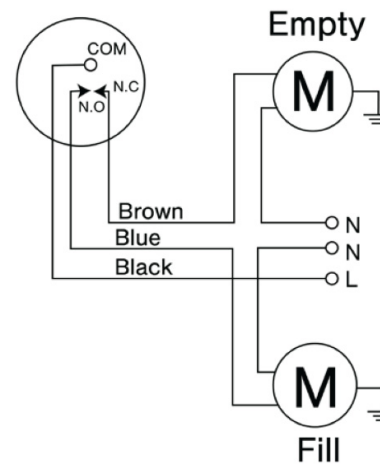
Connect the **brown** wire to the auto-empty pump.



	<p>This appliance is not intended for use by persons (including children) with reduced physical, sensory or mental capabilities, or lack of experience and knowledge, unless they have been given supervision or instruction concerning use of the appliance by a person responsible for their safety. Children should be supervised to ensure that they do not play with the appliance.</p>
	<p>The product must not be disposed of with normal household waste.</p> <p>Dispose of in accordance with local environmental regulations.</p>

Warranties – Terms and Conditions

This warranty is given in addition to the consumer guarantees found within the Australian Competition and Consumer Act 2010 (Cth) for goods purchased in Australia and the Consumer Guarantees Act 1993 NZ for goods purchased in New Zealand:



1) White International Pty Ltd / White International NZ Ltd (White International) warrant that all products distributed are free from defects in workmanship and materials, for their provided warranty period as indicated on the top or opposite side of this document. Subject to the conditions of the warranty, White International will repair any defective products free of charge at the premises of our authorised service agents throughout Australia and New Zealand if a defect in the product appears during the warranty period. If you believe that you have purchased a defective product and wish to make a claim under this warranty, contact us on our Sales Hotline on 1300 783 601, or send your claim to our postal address or fax line below and we will advise you as to how next to proceed. You will be required to supply a copy of your proof of purchase to make a claim under this warranty.

2) This warranty excludes transportation costs to and from White International or its appointed service agents and excludes defects due to non-compliance with installation instructions, neglect or misuse, inadequate protection against the elements, low voltage or use or operation for purposes other than those for which they were designed. For further information regarding the suitability of your intended application contact us on our Sales Hotline on 1300 783 601. If you make an invalid claim under this warranty, the original product will be sent back to you unrepai red.

3) This warranty refers only to products sold after the 1st January 2012, and is not transferable to another product type and only applies to the original owner, purchaser or end user, and is in addition to the consumer guarantees found within the Competition and Consumer Act 2010 (Cth) for goods purchased in Australia and the Consumer Guarantees Act 1993 (NZ) for goods purchased in New Zealand.

4) Our goods come with guarantees that cannot be excluded under the Australian Consumer Law. You are entitled to a replacement or refund for a major failure and for compensation for any other reasonably foreseeable loss or damage. You are also entitled to have the goods repaired or replaced if the goods fail to be of acceptable quality and the failure does not amount to a major failure.

5) To the fullest extent permitted by law, White International excludes its liability for all other conditions or warranties which would or might otherwise be implied at law. To the fullest extent permitted by law, White International's liability under this warranty and any other conditions, guarantees or warranties at law that cannot be excluded, including those in the Competition and Consumer Act 2010 (Cth), is expressly limited to: (a) in the case of products, the replacement of the product or the supply of equivalent product, the payment of the cost of replacing the product or of acquiring an equivalent product or the repair of the product or payment of the cost of having the product repaired, is at the discretion of White International or a 3rd party tribunal elected under the Competition and Consumer Act 2010 (Cth) for goods purchased in Australia and the Consumer Guarantees Act 1993 (NZ) for goods purchased in New Zealand; and

6) To the fullest extent permitted by law, this warranty supersedes all other warranties attached to the product or its packaging.

7) In the case of services, supplying the services again or the payment of the cost of having the services supplied again, is at the discretion of White International or a 3rd party tribunal elected under the Competition and Consumer Act 2010 (Cth) for goods purchased in Australia and the Consumer Guarantees Act 1993 (NZ) for goods purchased in New Zealand.

8) Our warranty commences from the date of purchase of the above-mentioned products. Proof of purchase is required before consideration under warranty is given.

*Print a copy of this page and record your date of purchase in the space below.
Retain the printed copy along with your purchase receipt for your records.*

Date of Purchase **Model Purchased**



www.whiteint.com.au

www.whiteint.co.nz

Please always refer to our website for further technical information & new product innovations

Disclaimer: Every effort has been made to publish the correct information in this manual. No responsibility will be taken for errors, omissions or changes in product specifications.

© 2026 Copyright White International Pty Ltd

TM ® - WARNING: Please be aware that various brands & products depicted within this document are subject to trademark, patent or design registrations. Infringement of any intellectual property contained within this document without express written authority by the appropriate intellectual property holder may result in further legal action to be taken. For any queries regarding use of the contained information please feel free to contact White International Pty Ltd.